

CPM 300/360



A new concept in
UPS Technology to revolutionise
power protection within Data Centres



Nothing protects quite like Piller

piller.com

Introducing the Piller Critical Power Module

The Piller Critical Power Module (CPM) has been designed with the specific needs of the modern enterprise data centre in mind, allowing designers to radically change their thinking for the provision of continuous power conditioning.

In the typical data centre, a significant proportion of power entering the building is lost on power conditioning, cooling and distribution before it reaches the IT load. These losses become compounded and have a major effect on financial performance: Reducing UPS losses delivers a wider impact on overall losses.

Construction and infrastructure costs are a significant part of the funding cycle for new data centres and the more complex the building project, the longer the construction time further adding to the capital burden.

A product that can positively address both capital and operating expenditure for a data centre will make a significant difference to the total cost of ownership.

ENERGY SAVING

The CPM concept brings together a highly efficient and reliable energy store with a five mode uninterruptible power system. There are two principle modes providing real power protection

combined with exceptional efficiency as high as 98%* and even higher efficiencies in ECO mode.

Efficiency improvements run throughout this design, however by integrating the energy store and utilising innovative cooling techniques, the CPM benefits from wide environmental operating characteristics that allow the elimination of air conditioning used in conventional battery systems. For cooling of the unit itself, the designer can choose between white space installation where use of the IT cooling system can be made and traditional plant room installation.

SPACE SAVING

By replacing batteries with an integrated energy store, up to 75% of the space normally taken up can be saved. Additional building space for battery air conditioning, switchgear and cabling is also eliminated.

The units can be mounted with power distribution units on pre-assembled skids for rapid deployment with minimal on-site commissioning and testing.

MINIMISED SERVICE

The Piller CPM has a very low-level maintenance regime compared with other systems. There are no battery inspections or autonomy tests to perform and major maintenance intervals are much longer than for most other systems. No substantial work is necessary within the first 10 years of service.

INNOVATIVE COOLING

Key elements of the CPM system are cooled by a self-contained heat exchange system that removes heat at the component surface more efficiently and effectively than conventional air cooling.

MODULAR/SCALABLE

CPM units can be configured in a variety of different ways even within the same data centre and systems of units can be extended to meet the increase in data centre loads with time. Scaling up the CPM system is more straightforward than a solution with batteries and requires little in the way of site preparation.

SOFTWARE TECHNOLOGY

A fully controllable and highly responsive power stage and energy store allows operation of the CPM to be optimised by algorithm according to pre-selection or auto-sensing. Further enhancement of low load efficiency is possible in multi-module systems by use of Enhanced Redundancy Mode (ERM) which optimises the number of units running whilst maintaining required redundancy levels.

COMMUNICATIONS AND MONITORING

In addition to all of the latest communication protocols and interfaces you might expect from Piller, the CPM comes complete with the option to install an Android or iOS App that gives authorised personnel an immediate and mobile status report for any CPM system anywhere in the world.**

*480V 60Hz without DC store. **Subject to network coverage and security settings. iOS is a registered trademark of the Apple Corp.



PILLER CPM 300/360

- Reduced Real Estate Requirements
- Increased net IT floor space
- Low service intervention and costs
- Increased availability by simplification
- Five operating modes
- Rapid deployment
- Reduced ancillary assets
- Increased critical power density
- Lower losses overall
- Guaranteed GenSet partnership
- Multiple power configurations
- Efficiency without compromise

KEY DATA

Voltage	380V-480V
Efficiency	up to 99%*
Frequency	50 & 60Hz
Dimensions (mm)	2450w x 900d x 1900h
Power Rating	300/360kW

OPERATING MODES

		Mains Operation	Generator Operation	Frequency Stabilisation	Voltage Stabilisation	Suppression
Mode 1	(VFI)	■	■	■	■	■
Mode 2	(VI)	■	■		■	■
Mode 3	(VFI2)		■	■	■	■
Mode 4	(VFD)	■	■			■
Mode 5	(ERM)	Applies to all Modes 1-4				

VFI – Voltage & Frequency Independent, VI – Voltage Independent, ECO – Voltage and Frequency Dependent.

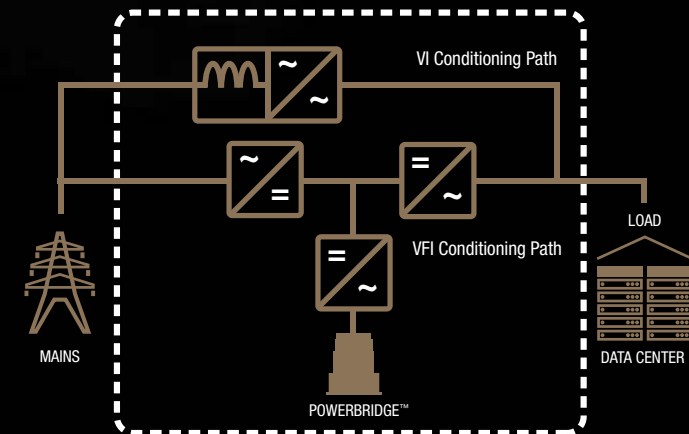

Piller CPM simplified schematic.



HEADQUARTERS

Piller Group GmbH

Abgunst 24
37520 Osterode
Germany
E: info@piller.com

ROTARY UPS SYSTEMS

HYBRID ROTARY UPS SYSTEMS

DIESEL ROTARY UPS SYSTEMS

STATIC UPS SYSTEMS

STATIC TRANSFER SWITCHES

KINETIC ENERGY STORAGE

AIRCRAFT GROUND POWER SYSTEMS

FREQUENCY CONVERTERS

NAVAL POWER SUPPLIES

SYSTEM INTEGRATION



A Langley Holdings Company



Piller Australia Pty. Ltd.

2/3 Salisbury Road, Castle Hill,
New South Wales 2154, Australia
T: +61 2 9894 1888
E: australia@piller.com

Piller France SAS

1 Avenue du Président Pompidou,
CS 70073 – BAT A,
F-92508 Rueil-Malmaison Cedex, France
T: +33 1 47 21 22 55
E: france@piller.com

Piller Germany GmbH & Co. KG

Abgunst 24, 37520 Osterode,
Germany
T: +49 5522 311 0
E: germany@piller.com

Piller Italia S.r.l.

Centro Direzionale Colleoni,
Palazzo Pegaso 3,
Viale Colleoni 25,
20041 Agrate Brianza (MB), Italy
T: +39 039 689 2735
E: italia@piller.com

Piller Iberica S.L.U.

Paseo de la Habana, 202 Bis B,
E-28036 Madrid, Spain
T: +34 91 345 86 58
E: spain@piller.com

Endurance Power Protection Pvt Ltd.

DCT 603, 6th Floor, DLF City Court,
Sikanderpur, MG Road, Gurgaon,
Haryana-122001, India
T: +91 12442 90262
E: india@piller.com

Piller Power Singapore Pte. Ltd.

25 International Business Park,
#01-65/66 German Centre,
Singapore 609916
T: +65 6562 9100
E: asiapac@piller.com

Piller UK Ltd.

Westgate, Phoenix Way, Cirencester,
Gloucestershire, GL7 1RY
United Kingdom
T: +44 1285 657 721
E: uk@piller.com

Piller Power Systems Inc.

45 Wes Warren Drive, Middletown,
New York 10941-2047, USA
T: +1 800 597 6937
E: usa@piller.com

Additional Piller offices in:

AUSTRIA | CANADA | CHINA | LATIN AMERICA | NETHERLANDS | SOUTH KOREA | SWEDEN | TAIWAN

Representatives and Distributors in:

ALGERIA | AUSTRIA | BAHRAIN | BELGIUM | BRAZIL | CANADA | CHILE | CHINA | EGYPT | HONG KONG
| INDONESIA | MALAYSIA | MEXICO | NETHERLANDS | NIGERIA | NORWAY | POLAND | ROMANIA |
RUSSIA | SLOVENIA | SOUTH KOREA | SUDAN | TAIWAN | THAILAND | TURKEY | UAE | USA

Nothing protects quite like Piller

piller.com

Piller CPM 300 (GB) 03 2017/Issue 2. Due to a policy of continued improvement, we reserve the right to change any specification without prior notice. ERRORS & OMISSIONS EXCEPTED.
Printed on a Manroland R700 press.